



**PURE**  
Humidifier

*“Read and Save These Instructions”*

*Deionized, Demineralized, or Reverse Osmosis Water*

# ***“ESDDR” Series Electric Humidifier***

**Installation Instructions**

---

**Operation and Maintenance Manual**

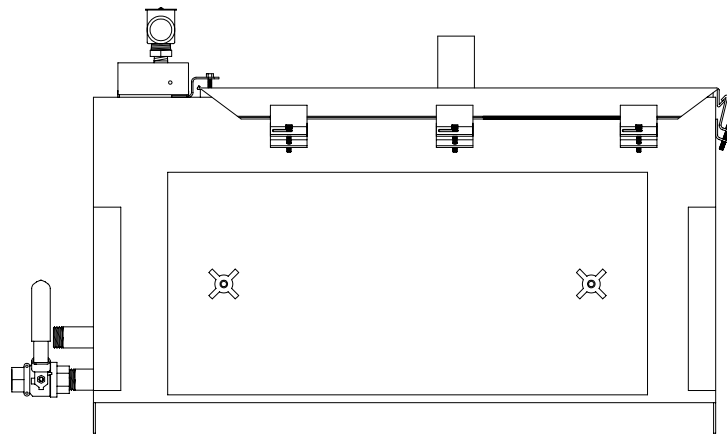

ETL LISTED HUMIDIFIER

*Our results are comforting*



# Introduction

## To the user of PURE Humidifier Co.'s Electric Humidifiers

We at PURE Humidifier Co. thank you for choosing one of our quality products. PURE Humidifier Co.'s "ESDDR" Series humidifiers are models of simplicity to install, operate and maintain. However, they must be maintained to provide maximum operating efficiency.

**PLEASE READ AND FOLLOW ALL INSTRUCTIONS CAREFULLY. PROPER OPERATION AND HUMIDITY CONTROL IS POSSIBLE ONLY WITH PROPER INSTALLATION AND MAINTENANCE.**

High chloride content in feed water can cause chloride stress cracking and chloride pitting in stainless components. Chloride stress corrosion cracking (CSCC) and chloride pitting of stainless steel components is not covered by warranty. Do not use hydrochloric acid descalers or bleach to clean the tank. Consult the factory if you are unsure about which chemical descaler to use.

The "ESDDR" Series Humidifier is designed to operate with deionized, demineralized, or reverse osmosis water. All components that will be in contact with the water are constructed of type 304 stainless steel, incoloy or corrosion resistant materials.

To ensure proper installation of this product, it must be installed by qualified HVAC and electrical contractors, and must be in compliance with local, state, federal, and governing codes. If installed improperly this product may cause damage to property, severe personal injury, or death as a result of electric shock, burns, and/or fire.

### The PURE Humidifier Co. Warranty

PURE Humidifier Co. guarantees its products to be free from defects in material and workmanship for a period of one year from the date of shipment; provided the product is properly installed, serviced, and put into the service for which it was intended.

PURE Humidifier Co. is obligated under the terms of this warranty to the repair or replacement of the defective part(s), excluding any labor charges, or to refund the purchase price at our option. PURE Humidifier Co. assumes no obligation for incidental or consequential damages. The above provisions are in lieu of all other guarantees, obligations, liabilities or warranties, expressed or implied.

## Table of Contents

Introduction	1
Internal Humidifier Features	1
Capacity & Weights	2
Layout and Dimensions	3
Electrical Specifications	4
Mounting/Location	5-6
Hose Kit Installation	7
Steam Piping Examples	8
Water Supply Piping	9
Start-Up Procedure	10
Maintenance Instructions	11
Trouble Shooting	12
Tool Requirements	13
Maintenance Notes	14
Exploded Parts Drawing	15
Parts List	16

## External Features of the PURE Humidifier Co. "ESDDR" Series Electric Humidifier

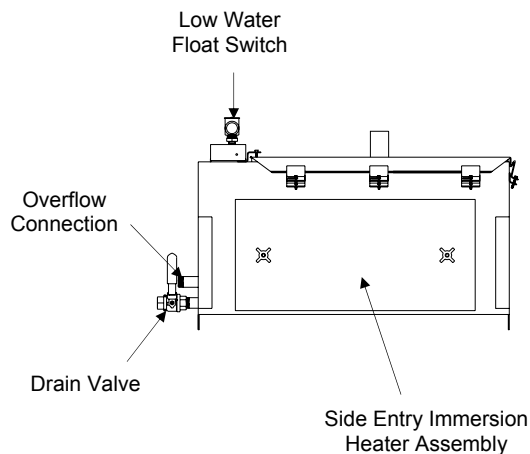



**PURE**  
Humidifier

## Capacities & Weights

Standard Water Unit Model No.	Steam Output Capacity †		KW	Humidifier Reservoir Weight*				Control Cabinet Weight Δ	
	lbs/hr	kg/hr		Empty		Full		lbs	kg
ESDDR-3	9.0	4.1	3	50.5	22.9	130.5	59.2	32.0	14.5
ESDDR-4.5	13.5	6.1	4.5	50.5	22.9	130.5	59.2	32.0	14.5
ESDDR-5.5	16.5	7.5	5.5	50.5	22.9	130.5	59.2	32.0	14.5
ESDDR-7.5	22.5	10.2	7.5	50.5	22.9	130.5	59.2	32.0	14.5
ESDDR-11	31.5	14.2	11	50.5	22.9	130.5	59.2	32.0	14.5
ESDDR-14	40.5	18.4	14	50.5	22.9	130.5	59.2	32.0	14.5
ESDDR-15	45.0	20.4	15	50.5	22.9	130.5	59.2	32.0	14.5
ESDDR-16.5	49.5	22.5	16.5	50.5	22.9	130.5	59.2	32.0	14.5
ESDDR-19.5	58.5	26.5	19.5	50.5	22.9	130.5	59.2	32.0	14.5
ESDDR-22	63.0	28.6	22	61.0	27.7	177.0	80.3	55.0	25.0
ESDDR-28	81.0	36.7	28	61.0	27.7	177.0	80.3	55.0	25.0
ESDDR-30	90.0	40.8	30	61.0	27.7	177.0	80.3	55.0	25.0
ESDDR-33	99.0	45.0	33	61.0	27.7	177.0	80.3	55.0	25.0
ESDDR-39	117.0	53.1	39	61.0	27.7	177.0	80.3	55.0	25.0
ESDDR-42	126.0	57.2	42	61.0	27.7	177.0	80.3	55.0	25.0
ESDDR-45	135.0	61.2	45	65.5	29.7	181.5	82.3	72.0	32.7
ESDDR-49.5	148.5	67.4	49.5	65.5	29.7	181.5	82.3	72.0	32.7
ESDDR-58.5	175.5	80.0	58.5	65.5	29.7	181.5	82.3	72.0	32.7
ESDDR-63	189.0	85.7	63	65.5	29.7	181.5	82.3	72.0	32.7
ESDDR-66	198.0	89.8	66	88.0	39.9	243.0	110.2	72.0	32.7
ESDDR-78	234.0	106.1	78	88.0	39.9	243.0	110.2	72.0	32.7
ESDDR-84	252.0	114.3	84	88.0	39.9	243.0	110.2	72.0	32.7
ESDDR-102	306.0	138.8	102	88.0	39.9	243.0	110.2	72.0	32.7

\* When calculating the total dry weight of the humidifier, the control cabinet weight must be added to the reservoir weight.

Δ The control cabinet is shipped loose unless optional factory mounting is specified. Reference the "Dimension Sheet" for control cabinet dimensions.

† The above capacities are based on 100% efficiency. Actual humidifier capacity may vary due to the heat loss from the humidifier reservoir. The ambient air temperature, air velocity, and injection tube system will affect the rate of heat loss from the humidifier reservoir.



# Dimensions & Layout

## NEMA- 12 Humidifier Control Cabinet (reference control cabinet notes)

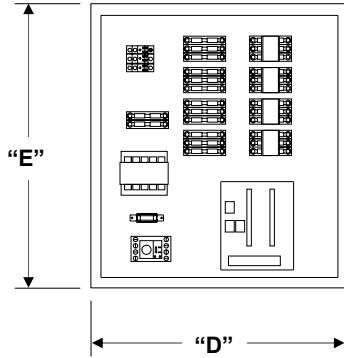

1. Door has been removed from the drawing for clarity.
2. Control cabinet is shipped loose for field mounting unless optional factory mounting is specified.
3. Dimension "F" = Control cabinet depth.

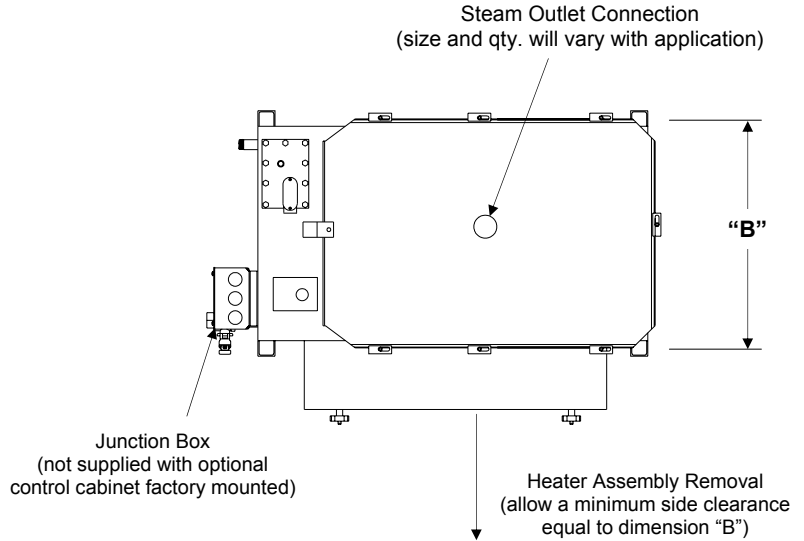

**Top View**

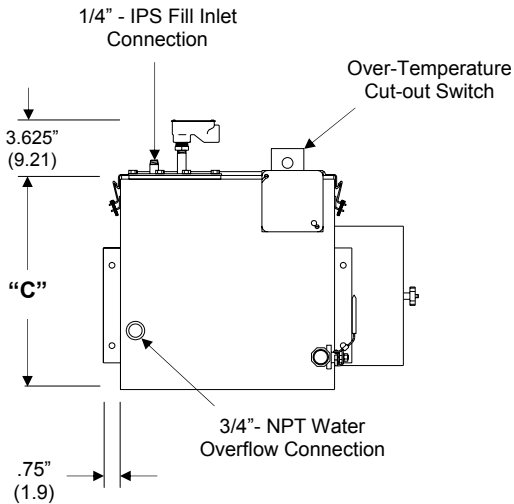

**Front View**

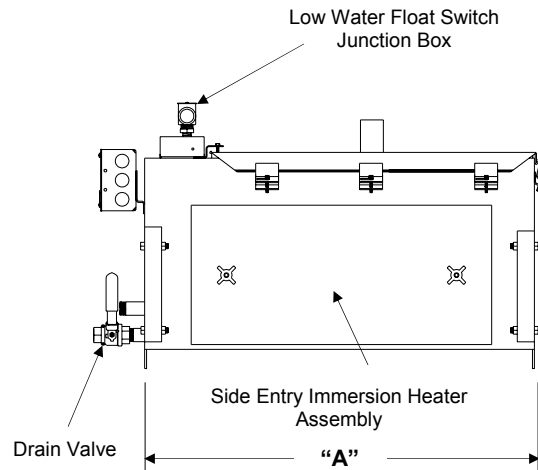

**Right Side View**

### Unit Dimensions in inches (cm)

Model Number	Dim. "A"	Dim. "B"	Dim. "C"
ESDDR-3 thru 19.5	17.50" (44.5)	14.00" (35.6)	13.75" (34.9)
ESDDR-22 thru 63	25.50" (64.8)	14.00" (35.6)	13.75" (34.9)
ESDDR-66 thru 102	34.00" (86.4)	18.25" (46.4)	13.75" (34.9)

### Control Cabinet Dimensions in inches (cm)

Model Number	Dim. "D"	Dim. "E"	Dim. "F"
ESDDR-3 thru 19.5	14.00" (35.6)	16.00" (40.6)	6.00" (15.2)
ESDDR-22 thru 63	20.00" (50.8)	20.00" (50.8)	7.00" (17.8)
ESDDR-66 thru 102	20.00" (50.8)	24.00" (61.0)	7.00" (17.8)



**PURE**  
Humidifier

## Electrical Specifications

### Single Phase Amperage†

Standard Water Unit Model No.	Unit KW	120V	208V	240V	480V	600V	No. of Heaters	Heater KW	Control Circuit Voltage
ESDDR-3	3	25.0	14.4	12.5	6.3	5.0	1	3.0	24 vac
ESDDR-4.5	4.5	37.5	21.6	18.8	9.4	7.5	1	4.5	24 vac
ESDDR-5.5	5.5	45.8	26.4	22.9	11.5	9.2	1	5.5	24 vac
ESDDR-7.5	7.5		36.1	31.3	15.6	12.5	3	2.5	24 vac
ESDDR-11	11				22.9	18.3	2	5.5	24 vac
ESDDR-14	14				29.2	23.3	2	7.0	24 vac
ESDDR-15	15				31.3	25.0	3	5.0	24 vac
ESDDR-16.5	16.5				34.4	27.5	3	5.5	24 vac
ESDDR-19.5	19.5				40.6	32.5	3	6.5	24 vac
ESDDR-22	22			91.7	45.8	36.7	4	5.5	24 vac
ESDDR-28	28				58.3	46.7	4	7.0	24 vac
ESDDR-30	30				62.5	50.0	6	5.0	24 vac
ESDDR-33	33				68.8	55.0	6	5.5	24 vac
ESDDR-39	39				81.3	65.0	6	6.5	24 vac
ESDDR-42	42				87.5	70.0	6	7.0	24 vac
ESDDR-45	45				93.8	75.0	9	5.0	24 vac
ESDDR-49.5	49.5				103.1	82.5	9	5.5	24 vac
ESDDR-58.5	58.5				121.9	97.5	9	6.5	24 vac
ESDDR-63	63				131.3	105.0	9	7.0	24 vac
ESDDR-66	66				137.5	110.0	12	5.5	24 vac
ESDDR-78	78				162.5	130.0	12	6.5	24 vac
ESDDR-84	84				175.0	140.0	12	7.0	24 vac
ESDDR-102	102				212.5	170.0	12	8.5	24 vac

### Three Phase Amperage†

Standard Water Unit Model No.	Unit KW	208V	240V	480V	600V	No. of Heaters	Heater KW	Control Circuit Voltage
ESDDR-3	3	8.3	7.2	3.6	2.9	3	1.0	24 vac
ESDDR-4.5	4.5	12.5	10.8	5.4	4.3	3	1.5	24 vac
ESDDR-5.5	6.0	16.6	14.4	7.2	5.8	3	2.0	24 vac
ESDDR-7.5	7.5	20.8	18.0	9.0	7.2	3	2.5	24 vac
ESDDR-11	10.5	29.1	25.3	12.6	10.1	3	3.5	24 vac
ESDDR-14	13.5	37.5	32.4	16.2	13.0	3	4.5	24 vac
ESDDR-15	15	41.6	36.1	18.0	14.4	3	5.0	24 vac
ESDDR-16.5	16.5	45.8	39.7	19.8	15.9	3	5.5	24 vac
ESDDR-19.5	19.5		46.9	23.5	18.8	3	6.5	24 vac
ESDDR-22	21	58.3	50.5	25.3	20.2	6	3.5	24 vac
ESDDR-28	27	75.0	64.9	32.5	26.0	6	4.5	24 vac
ESDDR-30	30	83.3	72.2	36.1	28.9	6	5.0	24 vac
ESDDR-33	33	91.6	79.4	39.7	31.8	6	5.5	24 vac
ESDDR-39	39		93.8	46.9	37.5	6	6.5	24 vac
ESDDR-42	42			50.5	40.4	6	7.0	24 vac
ESDDR-45	45	124.9	108.3	54.1	43.3	9	5.0	24 vac
ESDDR-49.5	49.5	137.4	119.1	59.5	47.6	9	5.5	24 vac
ESDDR-58.5	58.5		140.7	70.4	56.3	9	6.5	24 vac
ESDDR-63	63			75.8	60.6	9	7.0	24 vac
ESDDR-66	66	183.2	158.8	79.4	63.5	12	5.5	24 vac
ESDDR-78	78		187.6	93.8	75.1	12	6.5	24 vac
ESDDR-84	84			101.0	80.8	12	7.0	24 vac
ESDDR-102	102			122.7	98.2	12	8.5	24 vac

† Other voltages available upon request. Please consult factory for specific availability.



## Location & Mounting

### Location

The location selected must provide for electrical service, cold or hot water supply, and sanitary drain.

When selecting a location, try to keep the humidifier within 10 feet (305 cm) of the duct to avoid unnecessary heat losses and condensation within the steam supply line.

Visible “fog” will saturate and condense when it contacts objects such as turning vanes, filters, fans, elbows, or take-offs. The warmer the air, the more easily it will dissipate the visible steam. The most active and warmest portion of the duct will provide better mixing of the steam and air. The injection tube should be mounted a minimum of 2 feet (61 cm) downstream from an elbow or other turbulent air flow area.

Avoid mounting the injection tube closer than 8-10 feet (244-305 cm) upstream of objects that could become saturated and condense the steam (reference the paragraph above). If the duct layout does not provide a straight unobstructed run of 8-10 feet (244-305 cm), a multiple injection tube system should be considered to reduce the visible steam travel distance.

### Location of Controls

It is important to avoid mounting any controls within the visible steam. The controls should be mounted a minimum of 8-10 feet (244-305 cm) downstream from the humidifier injection tube. Due to the temperature rise that exists within the visible steam dissipation area, thermostats should not be mounted near the injection tube. High-limit humidistats should be installed before any duct obstruction to make sure the humidifier is interrupted before saturation can occur on the object. The high-limit should be mounted a minimum of 8-10 feet (244-305 cm) downstream from the injection tube.

### Mounting

The humidifier should be mounted dead level in both directions. PURE Humidifier Co. recommends that the humidifier be mounted using one of the following three methods (ref. page 6):

1. Mounted on the wall. PURE Humidifier Co. offers wall mounting brackets as an option. The wall bracket installation sheet should be followed when installing the brackets.
2. Mounted off the floor with floor legs. PURE Humidifier Co. offers floor support legs as an option. The humidifier is mounted 24” (61 cm) up from the floor. Simple floor legs can be constructed from 1-1/4” x 1-1/4” x 1/4” angle iron. The support legs should be secured to the humidifier side mounting holes.

### Drain Pan Mounting

A drain pan is an additional safety feature which would be required to be supplied in the field. In a proper humidifier installation, a drain pan is not required. However, if the humidifier and injection tube are located in an area that contains valuable equipment or is a water sensitive area, PURE Humidifier Co. recommends the addition of a drain pan under the humidifier and under the injection tube. The drain pan should extend past all edges of the humidifier and if installed in the duct, it should extend a minimum of 3 feet (91 cm) downstream from the injection tube. The pan should be of a size which is sufficient to retain sudden drainage of the humidifier’s contents. The pan should be drained to a sanitary drain.

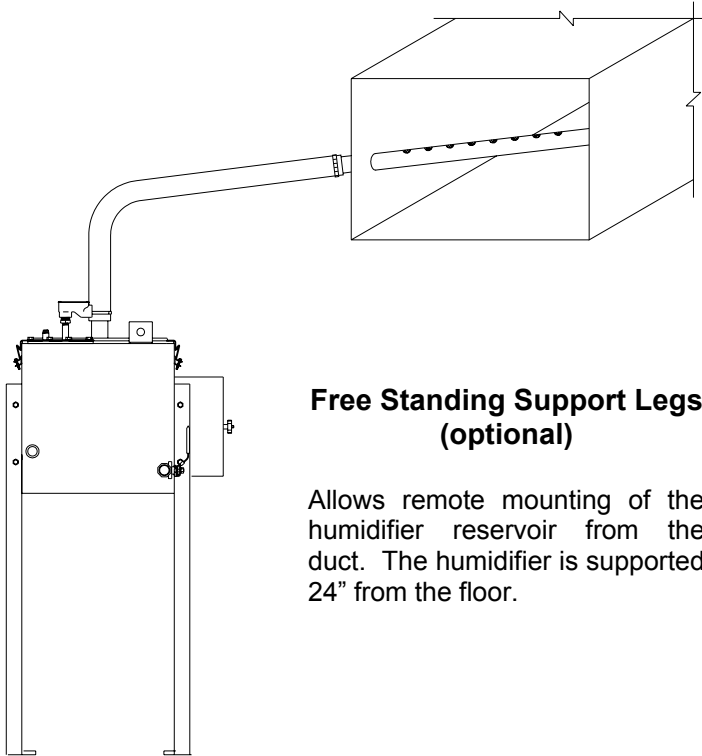

**Free Standing Support Legs  
(optional)**

Allows remote mounting of the humidifier reservoir from the duct. The humidifier is supported 24" from the floor.

The "ESDDR" Series Electric Humidifier offers a wide variety of mounting applications. If the duct is remote from the humidifier reservoir, free-standing floor support legs or wall brackets (both optional) are available. The humidifier can even be mounted directly within an air handling unit (local codes may require moisture proof construction of certain components). Single or multiple injection tubes can be used to custom fit any duct or air handler size.

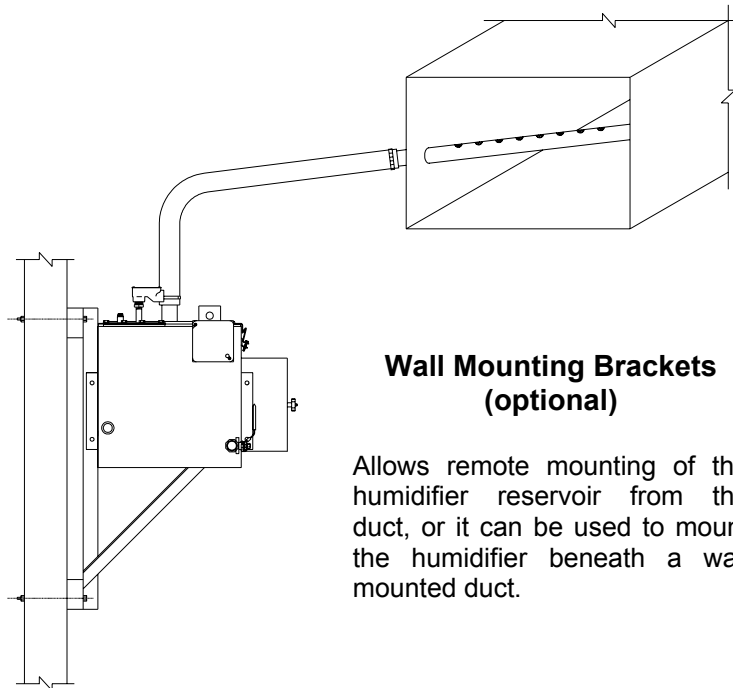

**Wall Mounting Brackets  
(optional)**

Allows remote mounting of the humidifier reservoir from the duct, or it can be used to mount the humidifier beneath a wall mounted duct.

## Flexible Hose Kit Installation

Hose kits should have the injection tube installed in the center of the duct. Hose and injection tube should be pitched back to the humidifier two inches (5 cm) per foot (31 cm). If proper pitch cannot be maintained, or the injection tube is mounted lower than the humidifier, a drain "tee" will be required (reference drain "tee" illustration).

Install the tube with the steam ports injecting steam up. **NOTE:** If narrow ducts (6"/15 cm or less, in height) are utilized, install the tube with the steam ports injecting slightly with the air flow (2 o'clock position)

The hose connects to the injection tube and humidifier with stainless steel hose clamps (by PURE Humidifier Co.).

Galvanized steel duct plates are provided to seal the opening where the tube enters the duct.

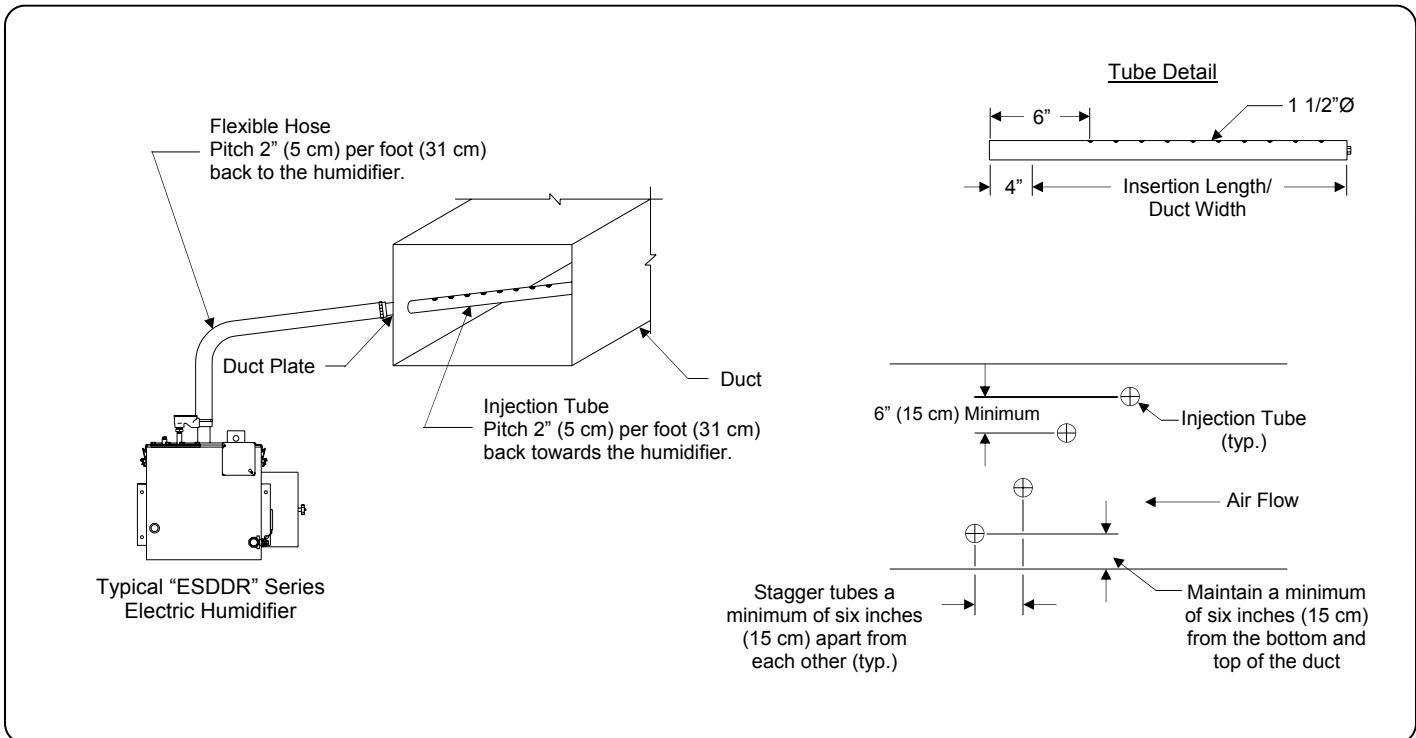
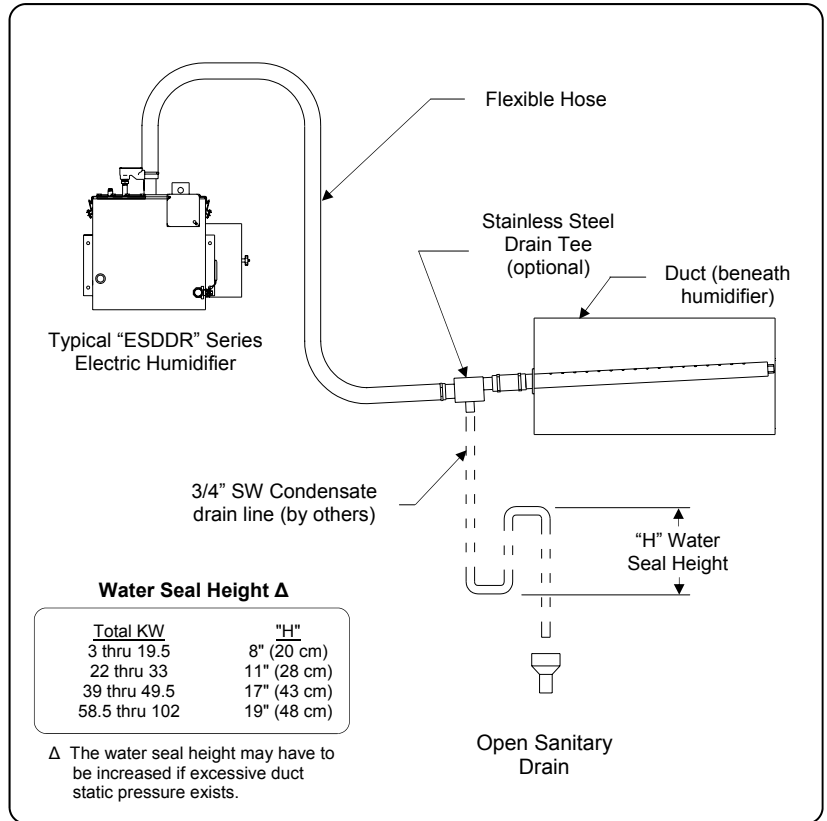



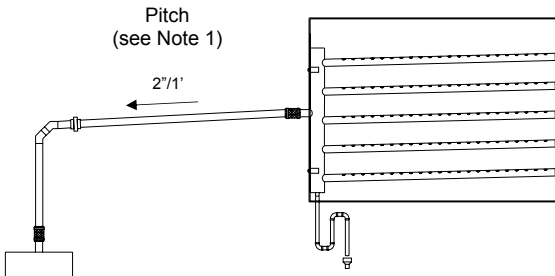

**Pitched Towards Steam Generator**

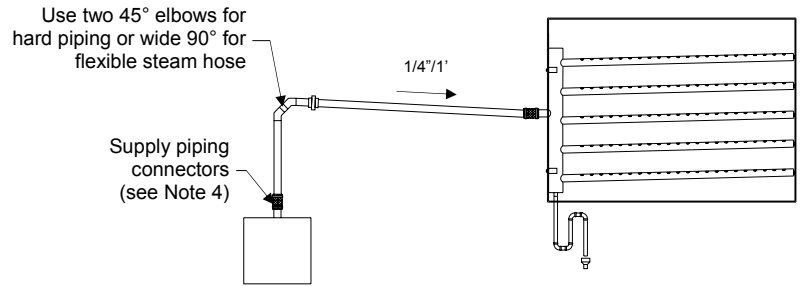

**Pitched Towards Tube Assembly**

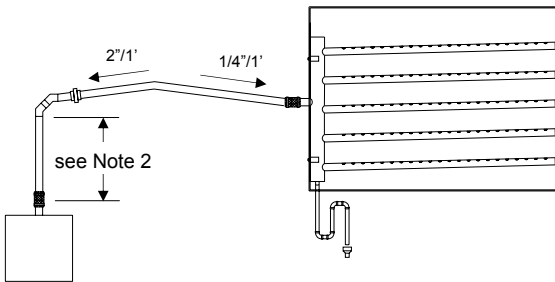

**Pitched Towards Steam Generator and Tube Assembly**

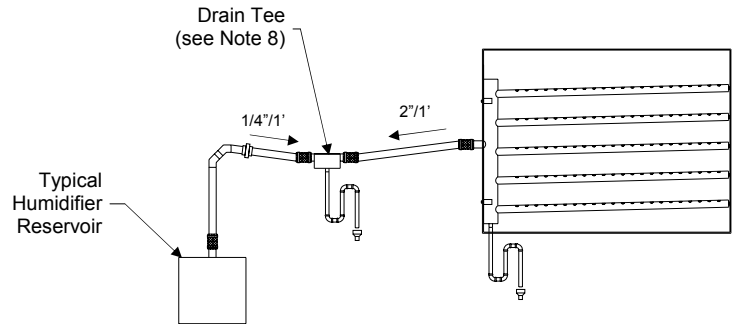

**Pitched Towards Drain Tee**

**Notes:**

1. Pitch hard piping or flexible hose 2" per foot if steam is flowing uphill, 1/4" per foot if the steam is flowing downhill. Reference piping examples shown.
2. When feasible to do so, install a minimum one-foot riser from the top of the tank to reduce condensate carry over.
3. Install union to allow for cover removal.
4. Use flex connectors or unions to allow for easy removal of cover.
5. Support flexible hose every 18" to avoid sagging.
6. Hard piping or flexible hose must match reservoir outlet size. Do not use supply piping with a smaller inside diameter than the reservoir outlet.
7. Failure to follow the piping recommendation on this page may result in blown water seals, leaking cover gasket or dispersion tubes spitting.
8. Install a Drain Tee at any low spots in supply piping run where condensate will accumulate.
9. Reference job specific tube assembly O&M included with your order for complete details.

## Water Supply Piping

This style humidifier utilizes a float operated fill valve system which is designed for use with deionized, demineralized, or reverse osmosis water. Use of mineralized tap water will cause fill valve failure and will void the humidifier warranty.

Cold or hot deionized, demineralized, or reverse osmosis water can be supplied to the humidifier. A minimum water pressure of 15 psi (1.03 Bar) should be maintained to provide the proper water level within the humidifier. If the water pressure is above 50 psi (3.5 Bar), water hammer could occur and a pressure reducing valve or shock arrester should be used. The humidifier has a factory built-in 1.5" (4 cm) air gap between the water inlet and the overflow. Local codes should be checked to see if the addition of the vacuum breaking device is required.

## Drain Piping

The "ESDDR" style humidifier requires two drain piping connections; a drain and an overflow connection. The drain lines should be piped together before the water seal as shown in the drain piping illustration.

A water seal (as shown in the piping illustration) should be installed to prevent steam from escaping through the drain line. The water seal should be of sufficient height to overcome the pressure developed in the humidifier (reference water seal height table) and the duct static pressure.

The drain piping should be copper or stainless steel. The use of PVC piping is not recommended; the humidifier temperature may cause the PVC to soften and fail.

If gravity drain is not possible please use a condensate pump rated for 212°F water or PURE Humidifier Co. Part No. 16033 Hartell A3X-115 condensate pump.

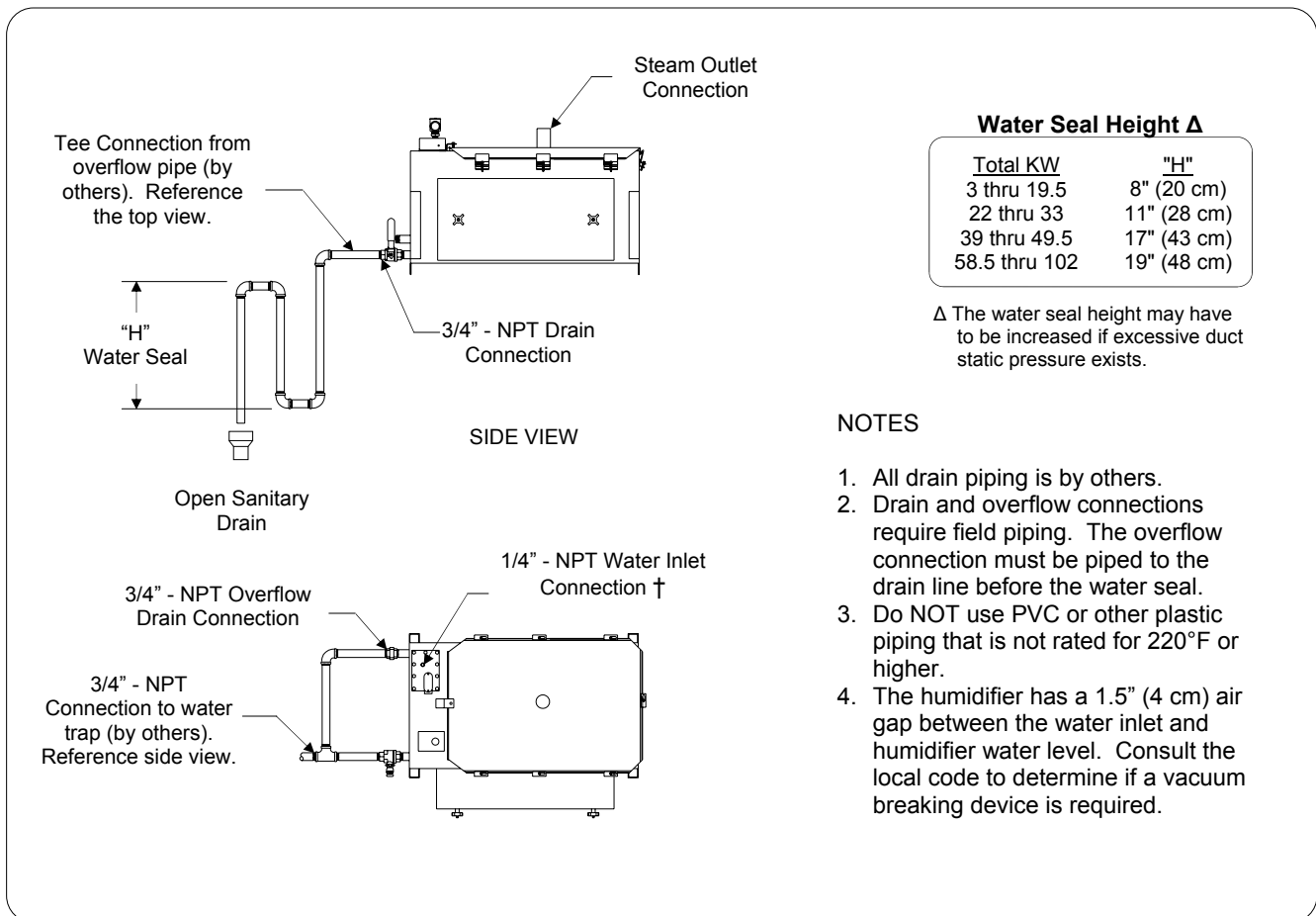



## Start-Up Procedure

### Introduction

Before starting the “ESDDR” PURE Humidifier Co. Electric Humidifier, check the following installation procedures:

1. MOUNTING – Verify that the humidifier evaporating chamber is securely supported and that the evaporating chamber is level in both directions.
2. INJECTION TUBE - Verify that the humidifier injection tube is mounted within the duct with the proper pitch back to the humidifier (2”/5 cm per foot/31 cm). NOTE: If the humidifier evaporating chamber or the flexible hose (optional) is mounted higher than the injection tube, a drain “Tee” is required to drain the condensate out of the injection tube and steam line.
3. ELECTRICAL - Verify that all wiring connections have been connected in accordance with the wiring diagram. **CAUTION: Live power may exist in the control cabinet. Turn off the main power at the disconnect switch before verifying the electrical connections!**
4. PIPING - Verify that all piping connections have been completed as recommended and that water pressure is available to the humidifier.
4. Open the water supply on/off control valve (by others) and allow the humidifier evaporating chamber to fill to the proper level.
5. After the humidifier is full of water, menu 004 will read “FULL”.
6. Verify the low water safety circuit by opening the manual drain lever on the drain valve. As the humidifier tank is draining, the "Fill" LED should illuminate. The humidifier should drain to a level where menu 004 reads “LOW”; this indicates that the low water safety circuit is operational.
7. Close the drain valve and allow the humidifier to fill to the proper level.
8. Make sure all the optional safety switches are satisfied (airflow proving switch, high-limit humidistat, etc.).
9. Turn menu 101 “RH Setpoint” up to a call for humidity.
10. The heater(s) should energize on a call from the humidistat or BMS.
11. Check operation of optional field-installed safety switches (airflow proving switch, high-limit humidistat, etc.) to make sure that they turn the power off to the control circuit power. The safety switches should shut-off the humidifier heaters whenever one or more of the optional safety switches create an “open circuit”.

### Start Up Procedure

1. Close the humidifier manual ball valve (located on the left side of the humidifier evaporating chamber faceplate).
2. Turn the electric power “on” to the humidifier. The LCD display on the INTAC® controller should illuminate “Normal Operation”.
3. Set menu 101 “RH Setpoint” to the lowest setting (no call for humidity). If 100 menu shows “No Parameters Available” the procedure must be done through the Building Management System.
12. Check heater amperage draw by testing and recording voltage and amperage in each phase. Readings should match the factory heater nameplate.
13. Inspect installation for leaks by operating humidifier. Any leaks should be sealed.



## Maintenance Instructions

### PURE Humidifier Co. “ESDDR” Maintenance Instructions

The “ESDDR” Series Humidifier is designed to provide the best possible operation with minimum maintenance. However, the humidifier should be inspected and placed on a dedicated maintenance schedule to ensure continued operation of the humidifier and its accessories. **PURE Humidifier Co. recommends that the following items be inspected and/or cleaned on a minimum basis of twice a year.** If excessive mineral build-up occurs, the maintenance schedule should be increased.

<u>Inspect / Maintenance Item</u>	<u>Procedure to Follow</u>
Water Make-up Float Valve	Check to make sure the fill valve is operating properly. If the valve appears to continually fill, check the valve seat and seal (see trouble shooting instructions).
Low Water Float Switch	Check to make sure the switch will shut the humidifier off when the water level drops too low. Open the drain valve to allow water to drain out for checking purposes. Make sure to reset the drain valve after inspection is completed.
Safety Interlocks (air flow, high-limit)	Check to make sure the safety interlocks (air flow, high-limit, etc.) will shut down the humidifier.
Immersion Heaters	Verify the correct amperage is being drawn by the heating element. Reference the wiring diagram for correct amperage.
Humidifier Cover / Tank	Inspect for any leaks. Repair as required. Remove the mineral deposits from floor of the humidifier reservoir. If excessive build-up is found, the cover may need to be removed to facilitate complete cleaning of the humidifier.
Flexible Hose	Inspect for cracks or leaks. It is normal for the hose to become hard and develop a “set”.



## *Trouble Shooting*

<b><u>Problem</u></b>	<b><u>Possible Cause</u></b>	<b><u>Recommended Action</u></b>
<b>Humidifier will not heat</b>	Blown heater fuse(s)	Check and replace.
	Control transformer not producing 24 vac control voltage	Check transformer output. Verify voltage across terminals #1 (hot) and #3 (comm).
	Safety controls open (air flow switch, high-limit, etc.)	Verify that all safety controls are completing the safety circuit.
	Faulty immersion heater	Check and verify heater voltage and amperage. Compare to diagram or nameplate label ratings.
<b>Humidifier will not fill</b>	No water pressure	Check water supply.
	Drain valve open	Close drain ball valve.
	Faulty water float valve	Check float valve seat for dirt.
<b>Humidifier will not stop filling or is short cycling</b>	Float valve stuck open	Check float valve seat for dirt. Adjust float ball arm.
	Drain valve open	Close drain ball valve.



## *Tool Requirements*

<b>Recommended Maintenance Tool List</b>
7/16" Wrench or Socket
5/8" Wrench
5/32" Nut Driver or Socket
5/16" Nut Driver or Socket
11/32" Nut Driver or Socket
3/8" Nut Driver or Socket
5/32" Allen head
Flat head screwdriver
Wire stripper
Wire crimper
Pipe wrench



*Maintenance Notes*

Maintenance Performed	Maintenance Notes	Date	By

NEMA-12 HUMIDIFIER CONTROL CABINET  
WITH DOOR OPEN

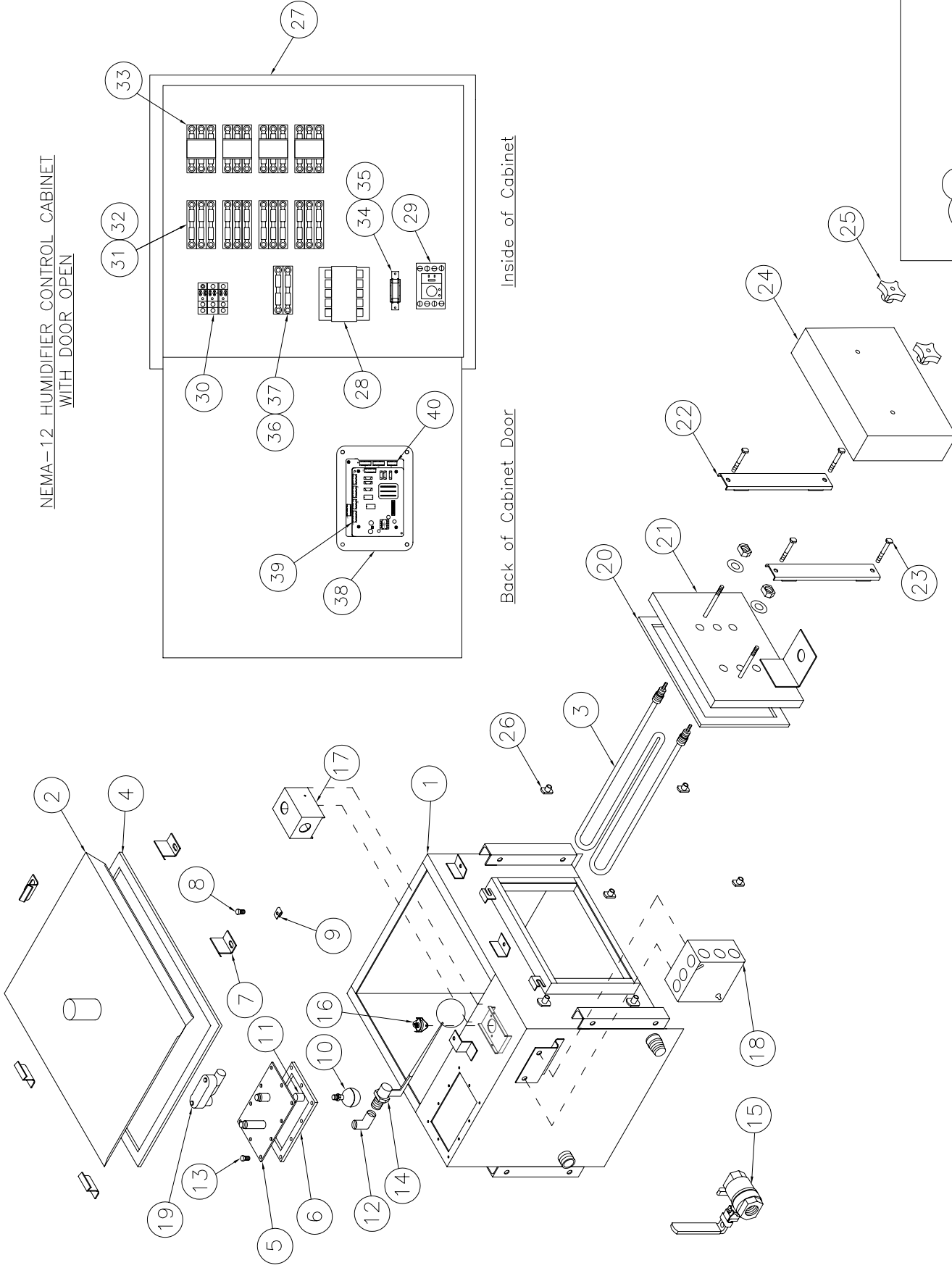

Back of Cabinet Door

Inside of Cabinet



Title: ESDDR SERIES ASSEMBLY

Scale: No Scale

Date: July 2, 2008

Drwn: P.R.G.

Dwg No: 1322



**PURE Humidifier Co. "ESDDR" Series  
Parts List & Two Year Recommended Spare Parts**

Item No.	Description	Part No.	Qty Per Unit	Rec. SpareQty.
1	ESDDR Reservoir Assembly	A	1	
2	ESDDR Reservoir Cover Assembly	A	1	
3	Immersion Heating Element(s)	A	A	
4	Cover Gasket	A	1	
5	DDR Float Plate Assembly	05407	1	
6	DDR Float Plate Gasket	05052	1	
7	Cover Clamp	15930	A	
8	Cover Clamp Screws	15522	A	
9	10-24 U Nut	15524	A	
10	Water Level Control Switch	15048	1	
11	1/4" Coupling 316 SST	07018	1	
12	1/4" 90 El. 316 SST	07019	1	
13	Float Plate Screws	15523	10	
14	Float Valve and Ball, 316 SST	A	1	
15	3/4" Ball Valve, 316 SST	09036	1	
16	Over Temp. Protector Switch	15047	1	
17	Over Temp. Switch Housing	15072	1	
18	Electrical Box	15076	1	
19	1/2" Junction Box	15079	1	
20	Heater Plate Gasket	A	1	
21	Heater Plate	A	1	
22	U-Clamp Bar	05238	A	
23	U-Clamp Blots	15526	A	
24	Heater Cover	A	1	
25	Heater Cover Knobs	15865	2	
26	1/4-20 Nut	15702	A	
27	Control Enclosure	A	1	
28	Step-Down Transformer	A	1	
29	Time Delay Relay	12022	1	
30	Power Distribution Block	A	A	
31	Fuse Block	A	A	
32	Heater Fuses	A	A	
33	Heater Contactors	A	A	
34	Control Circuit Fuse Holder	12085	1	
35	Control Circuit Fuse	A	1	
36	Secondary Fuse Holder	A	A	
37	Secondary Fuse	A	A	
38	INTAC <sup>®</sup> Microprocessor	12201	1	
39	7 Pin Terminal Connector	12310	A	
40	6 Pin Terminal Connector	12309	A	

**NOTES/CODES:**

A= Part Number and quantity vary with model number.

When ordering replacement or spare parts, please have the following information available: Model Number, Primary Voltage, Serial Number, No. of Heaters & Heater KW and any options ( ie, modulating control, insulation, etc. )







141 Jonathan Blvd. North  
Chaska, MN 55318  
Tel: (952) 368-9335 Fax: (952) 368-9338  
[www.purehumidifier.com](http://www.purehumidifier.com)